

---

# RealRoom(s)

---

2005

---

Project by fabric | ch

---

Client: Nestlé

---

Location: Vevey (CH)

---

Exhibited at Centre Culturel Suisse (Paris, FR), FILE Festival (Rio de Janeiro & Sao Paulo, BR), Mediaruimte (Brussels, BE)

---

- Nestlé world headquarters
  - Architectural retrofitting
  - Spatial displacements & streaming of the Earth's atmosphere and variations
  - Spatial devices connected to each of the 24-hour time zones,  $-180^{\circ}$  to  $+180^{\circ}$  longitudes,  $-90^{\circ}$  to  $+90^{\circ}$  latitudes
  - Global space & environmental unconditioning
- 

## - Video

for "Architecture invisible," Centre Culturel Suisse (Paris, FR).

Curator Philippe Rahm

# RealRoom(s)

Peripheral Architecture for the Nestlé World Headquarters,  
Vevey (Switzerland), 2005

[Img. 1]

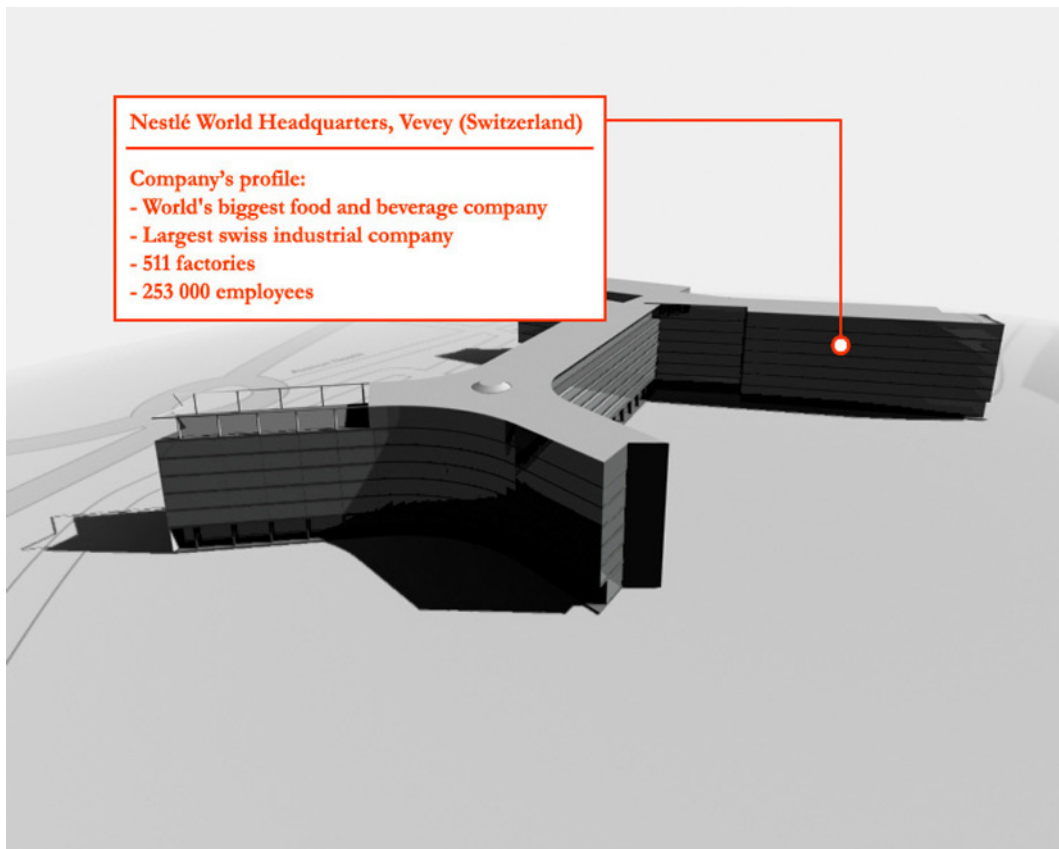

[Img. 2]



[Img. 3]

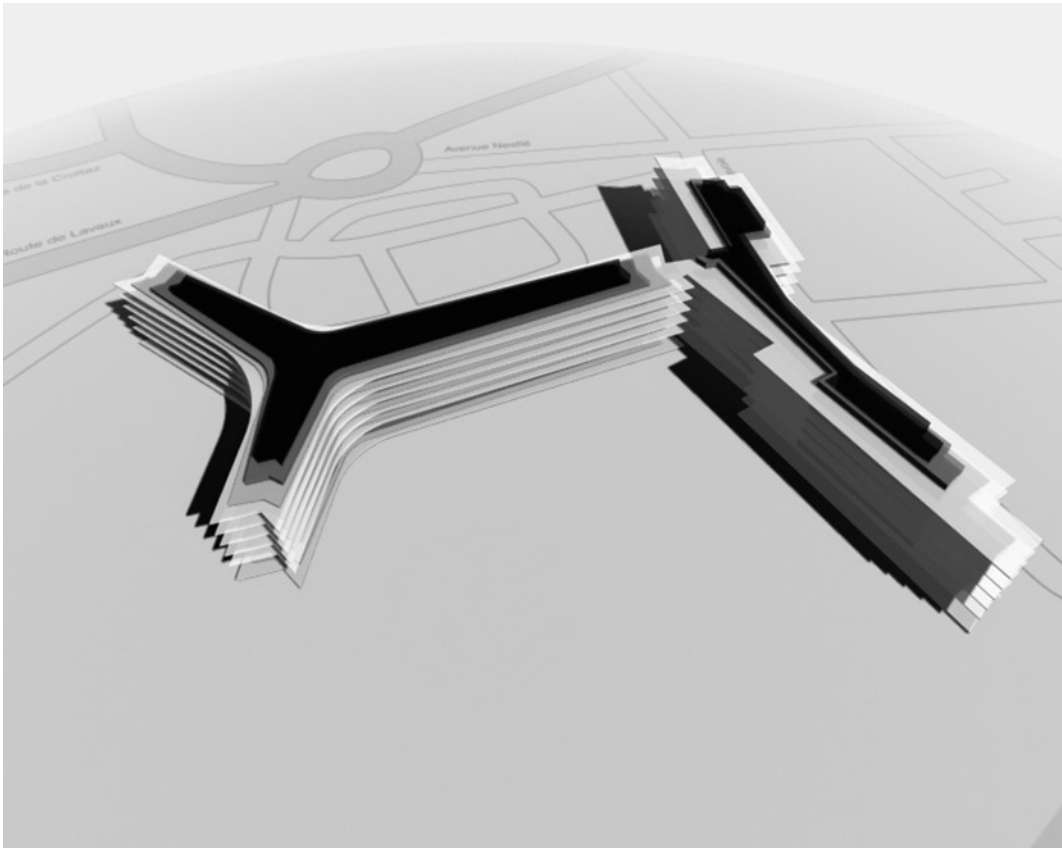

[Img. 4]

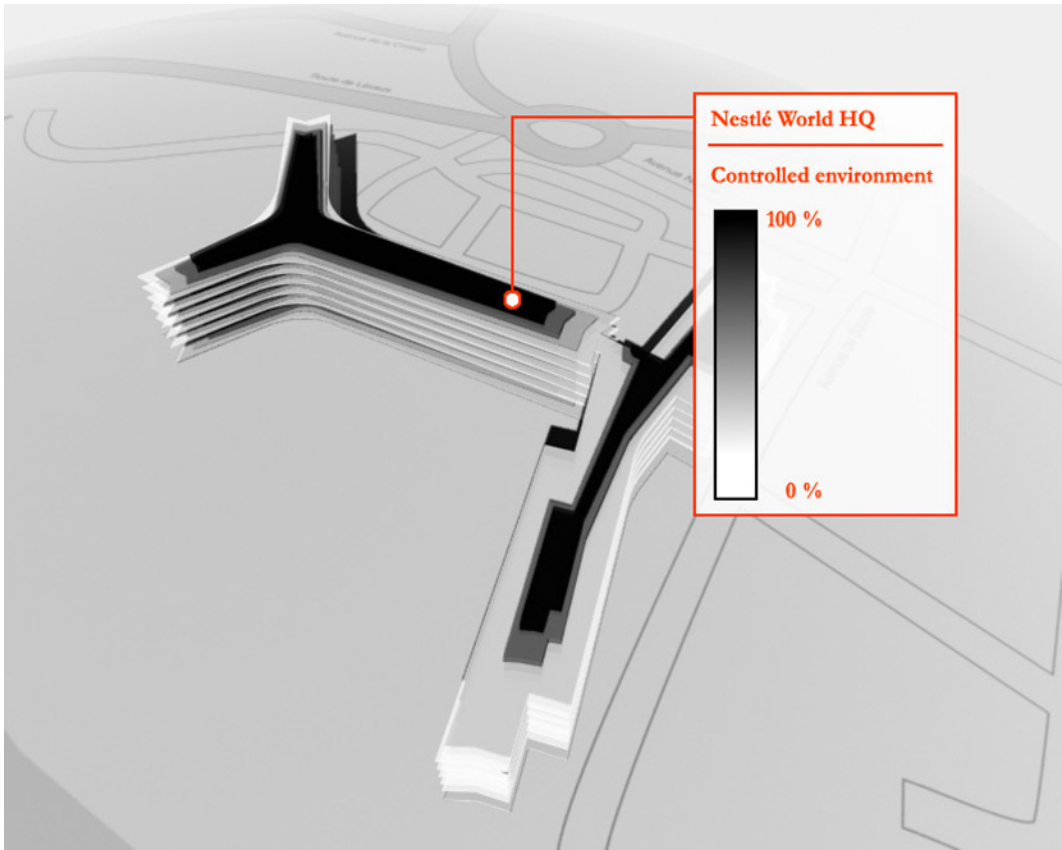

[Img. 5]

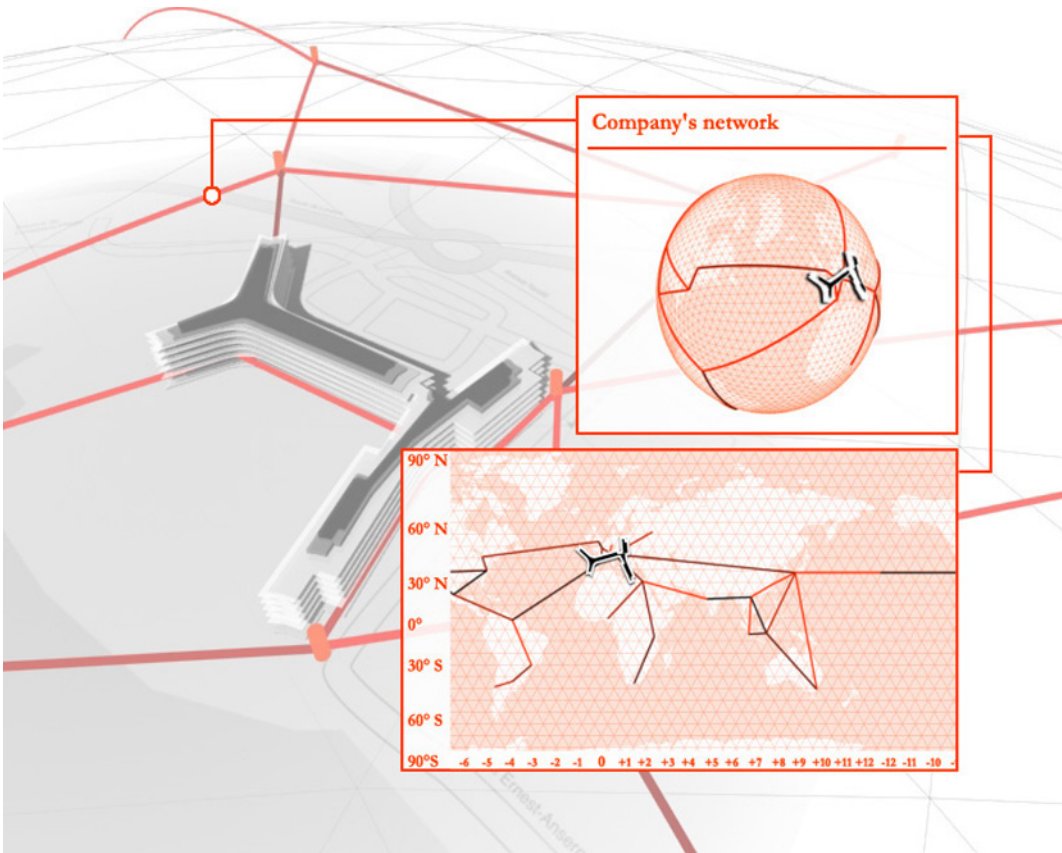

[Img. 6]

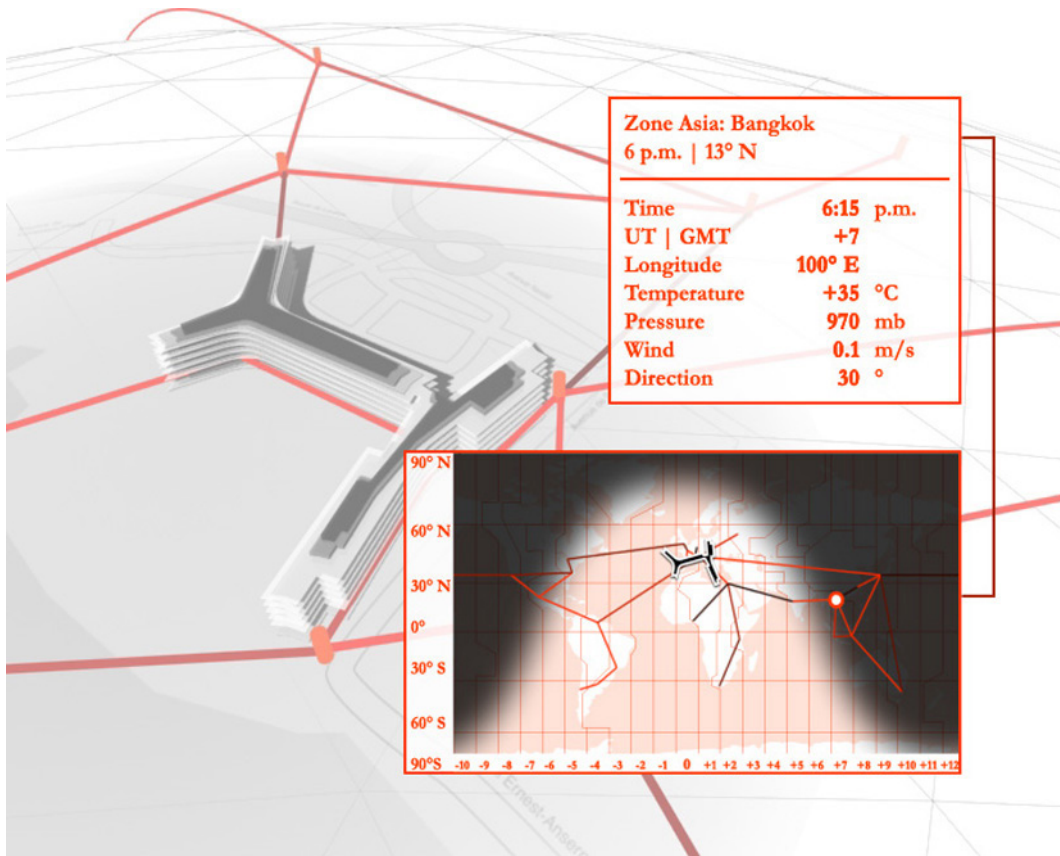

[Img. 7]



[Img. 8]

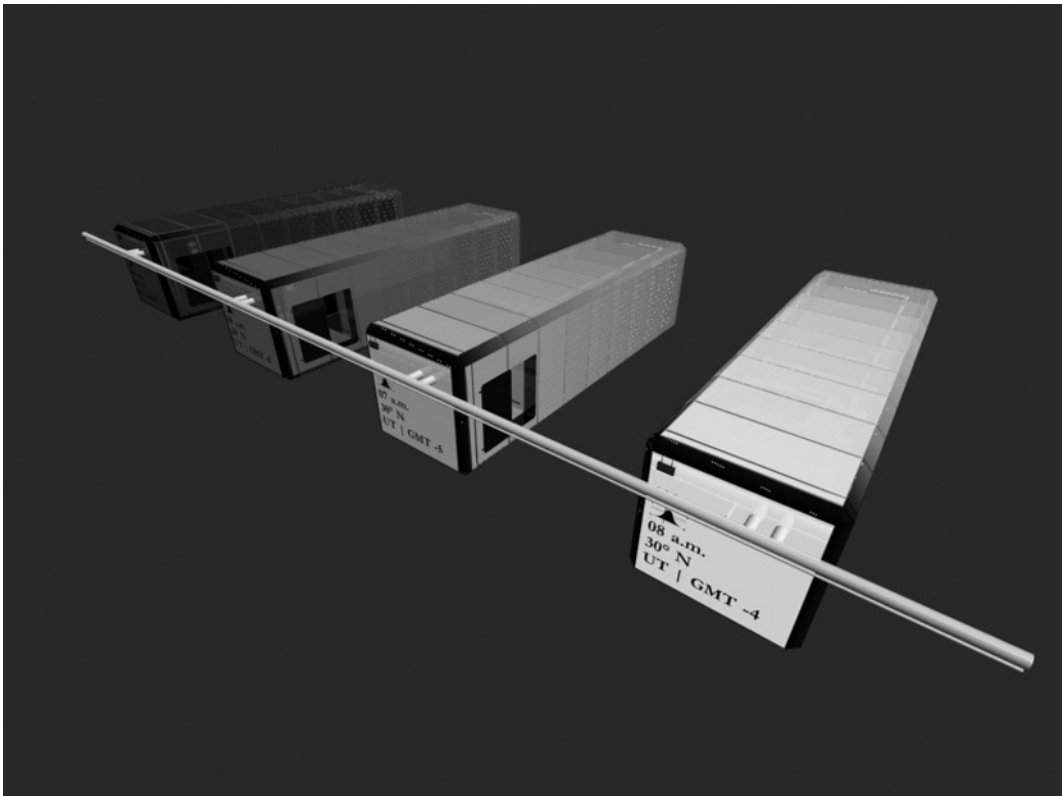

[Img. 9]

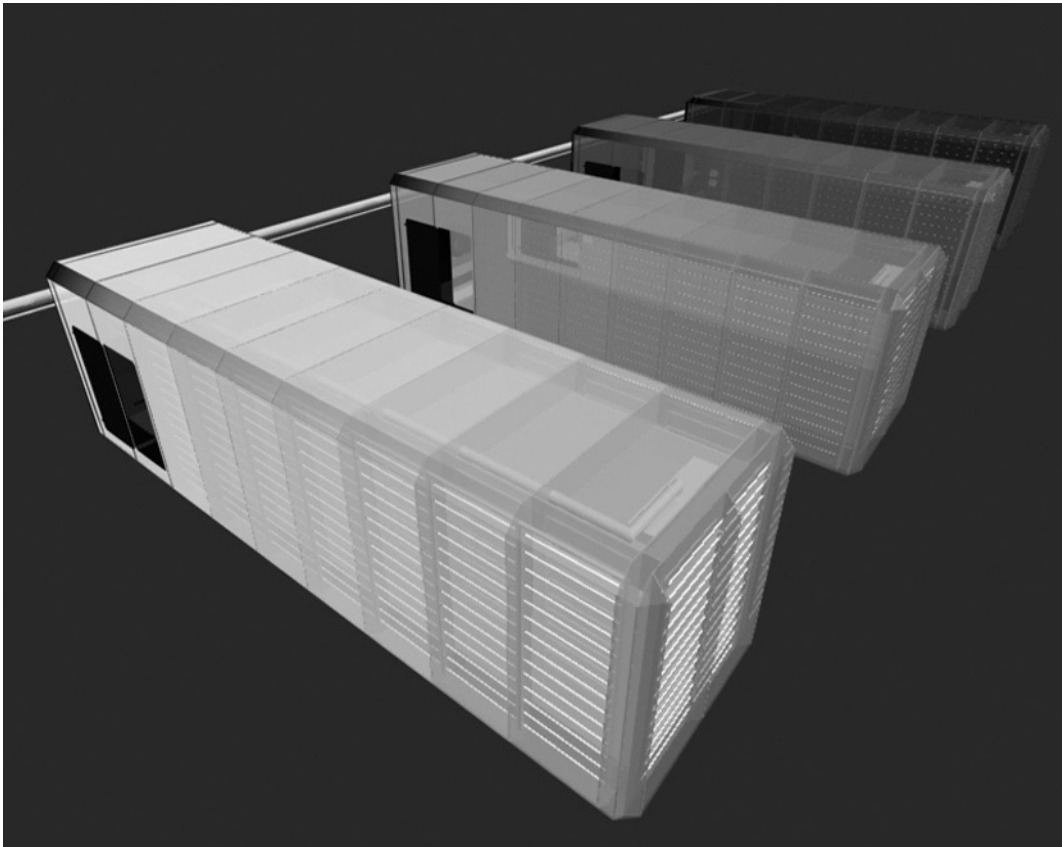

[Img. 10]



[Img. 11]

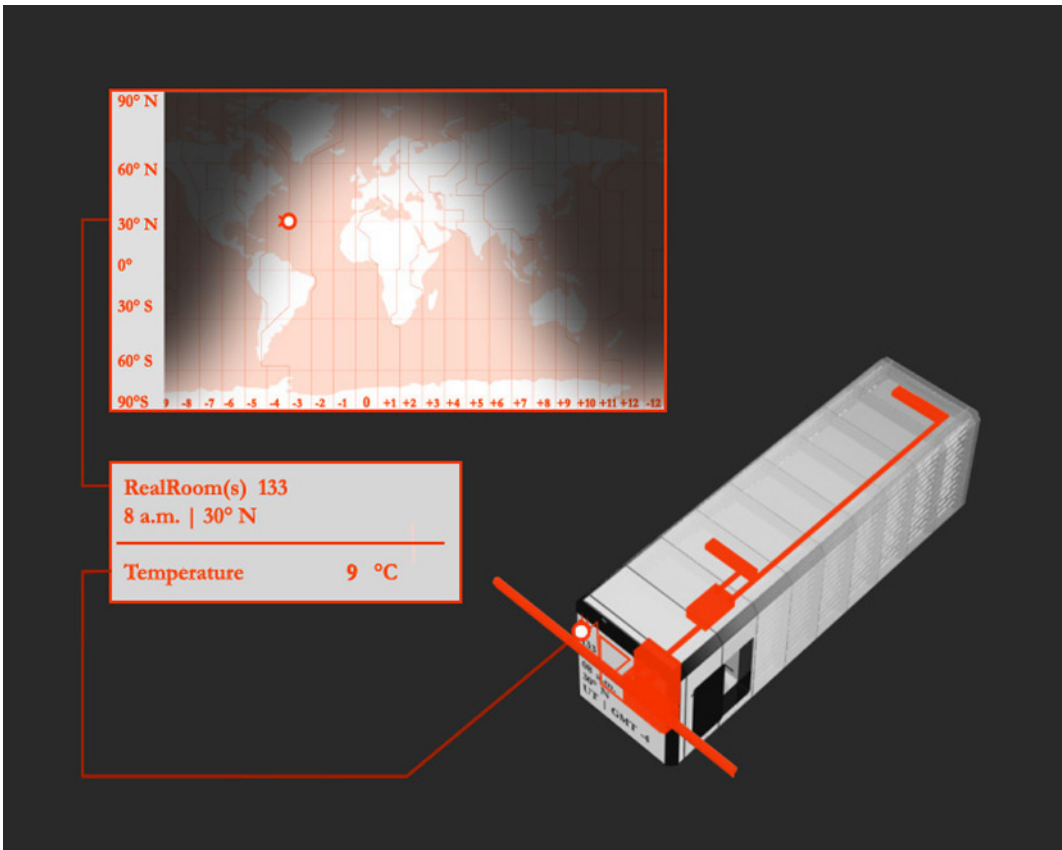

[Img. 12]

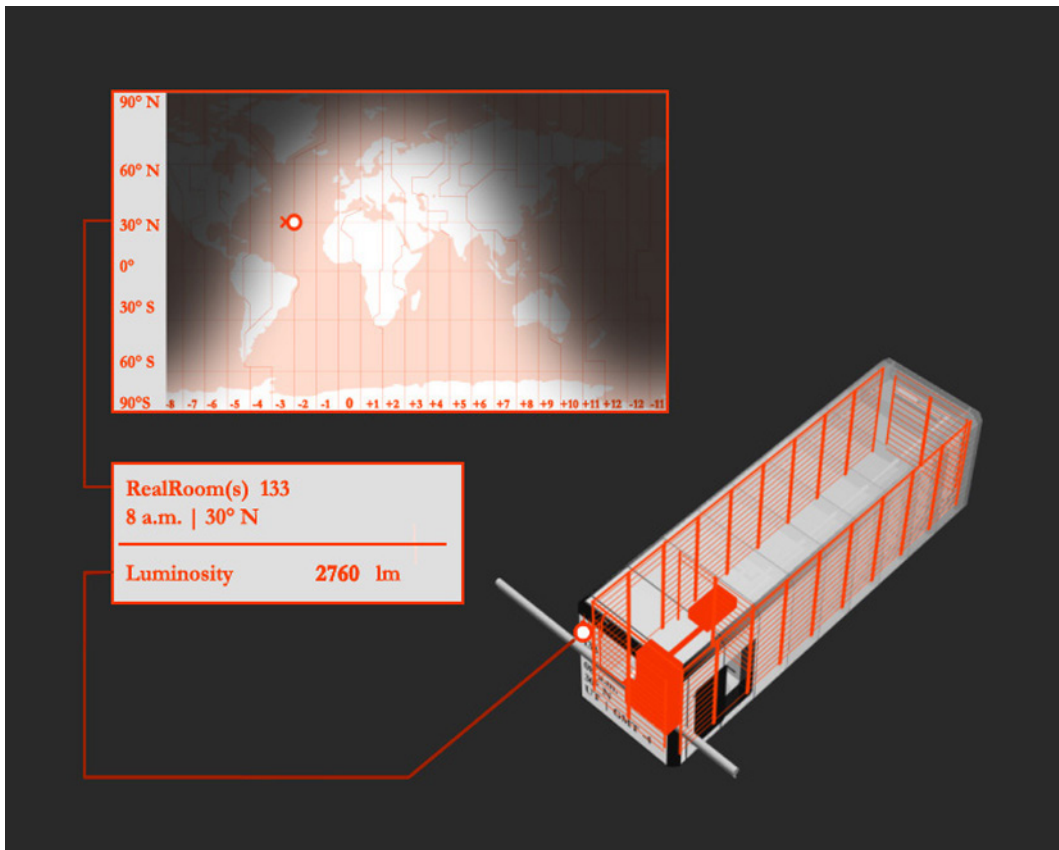

[Img. 13]

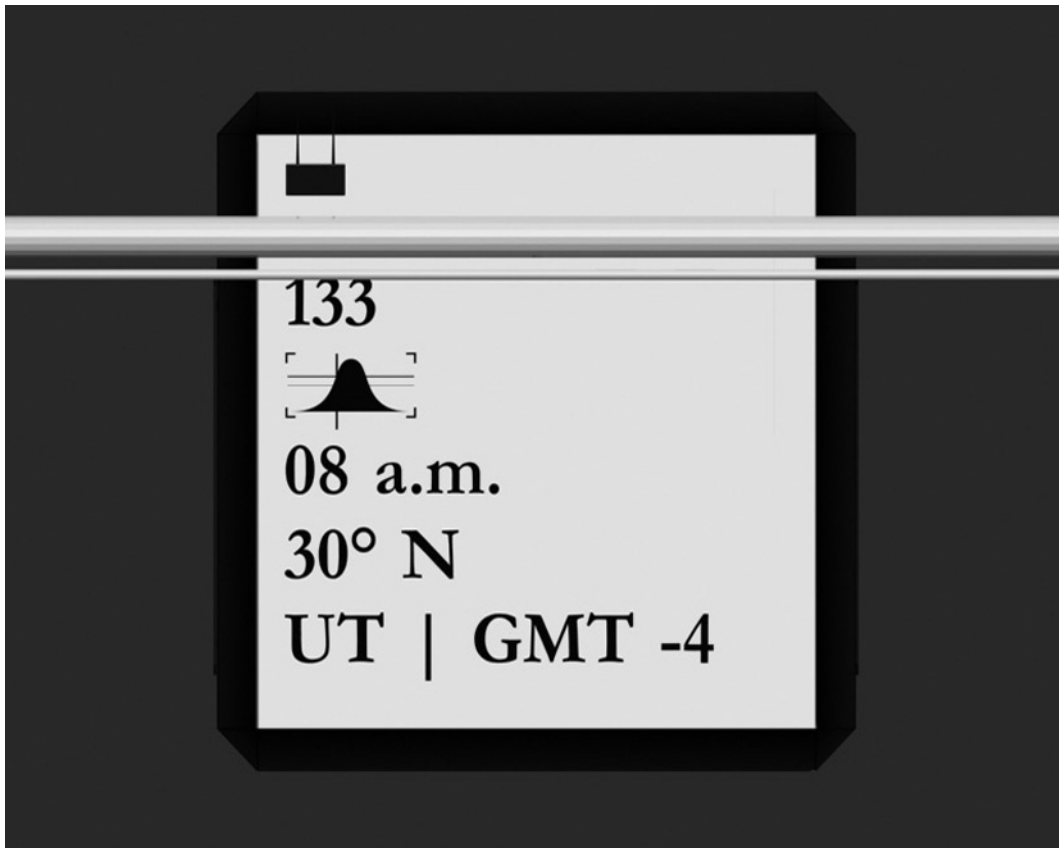

[Img. 14]

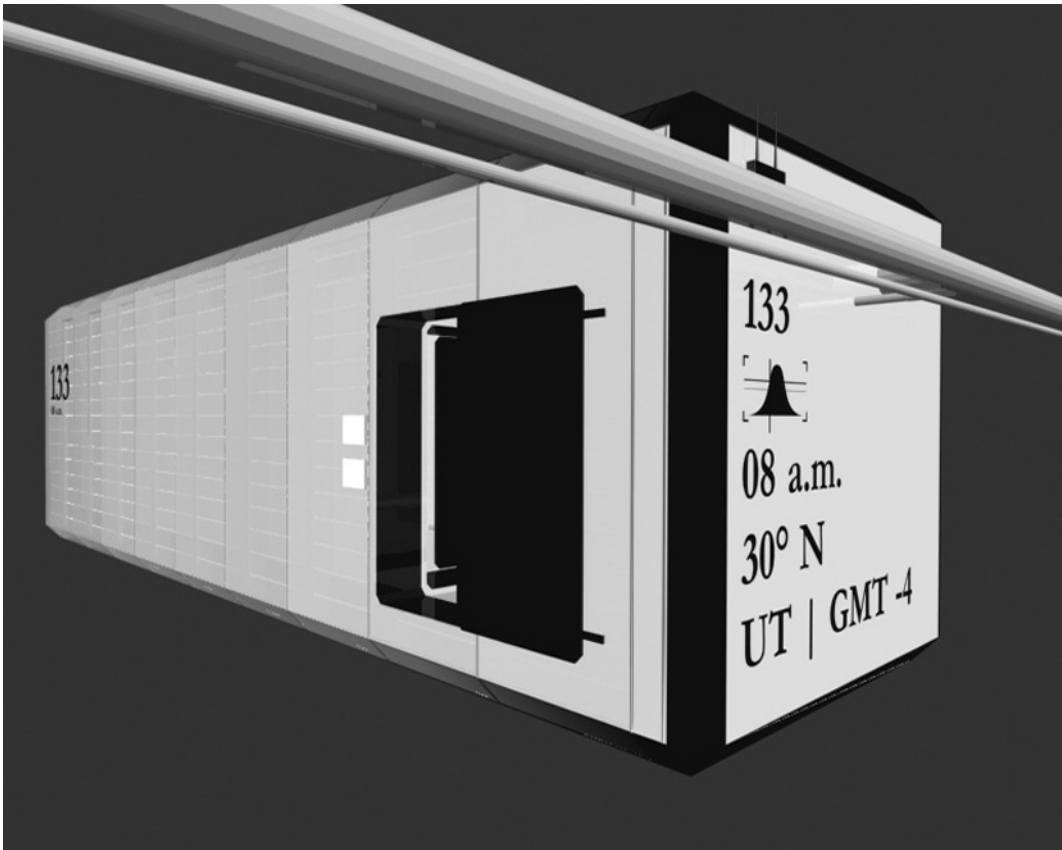

[Img. 15]

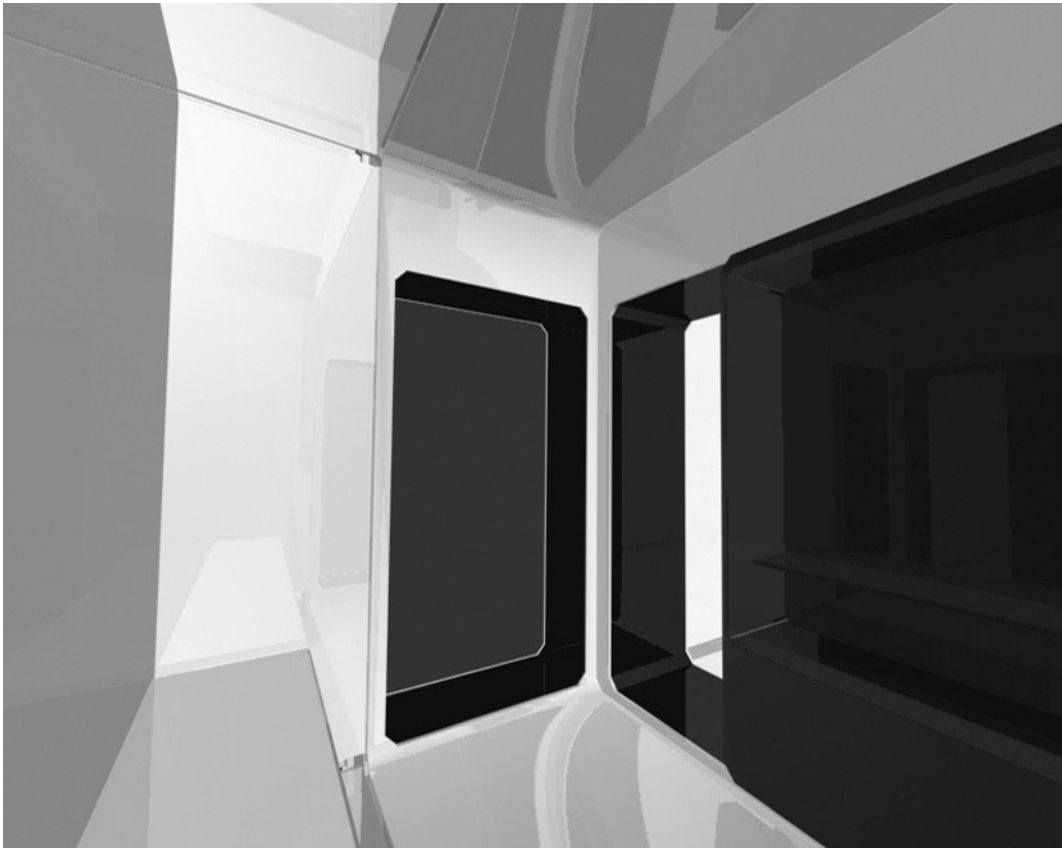

[Img. 16]

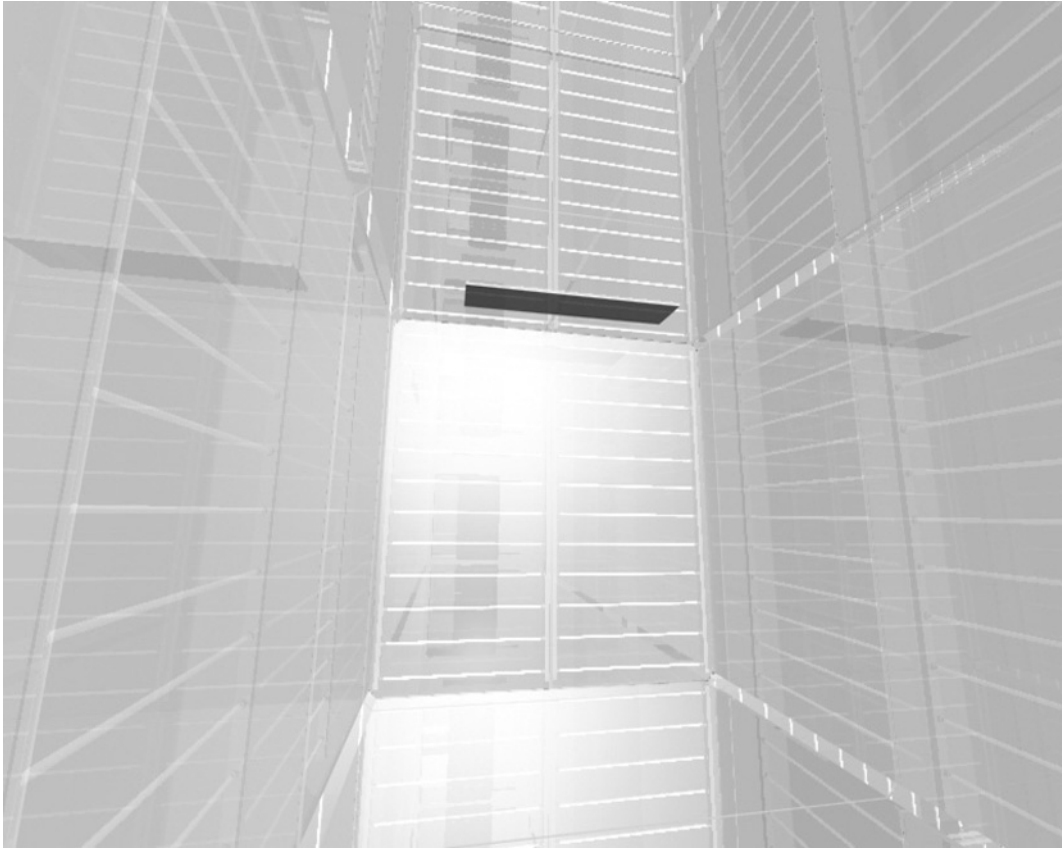

[Img. 17]

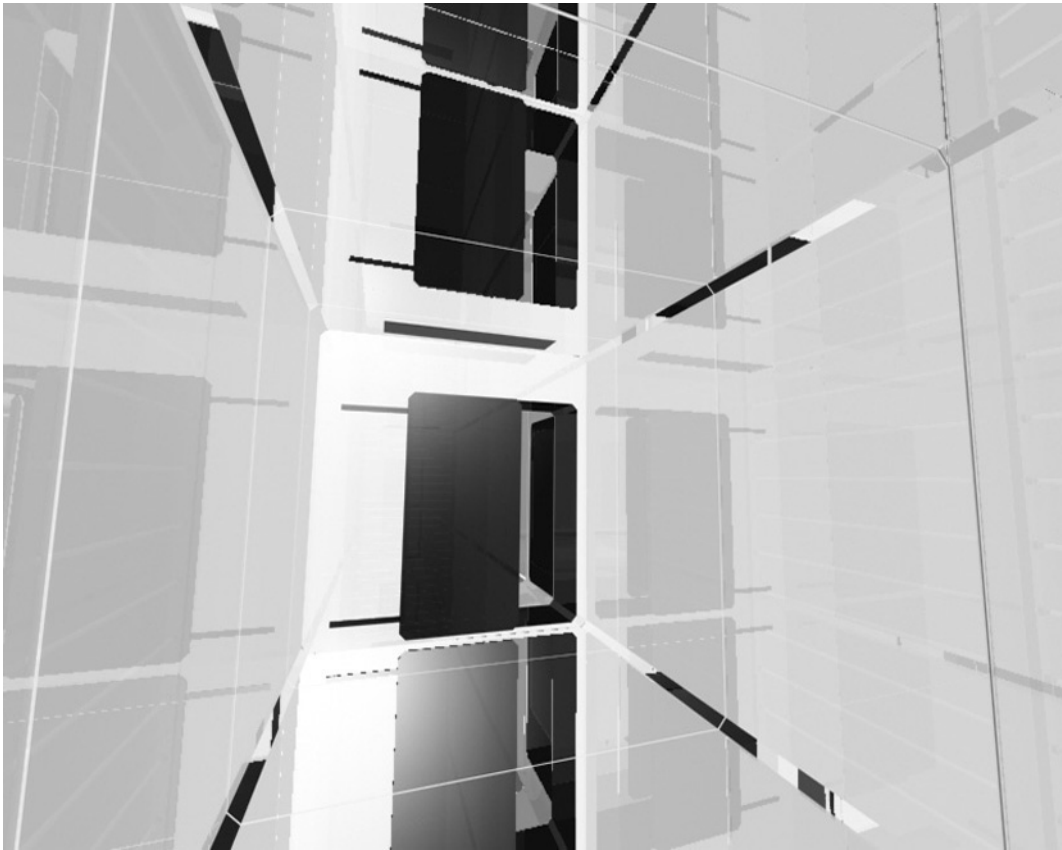

[Img. 18]



[Img. 19]

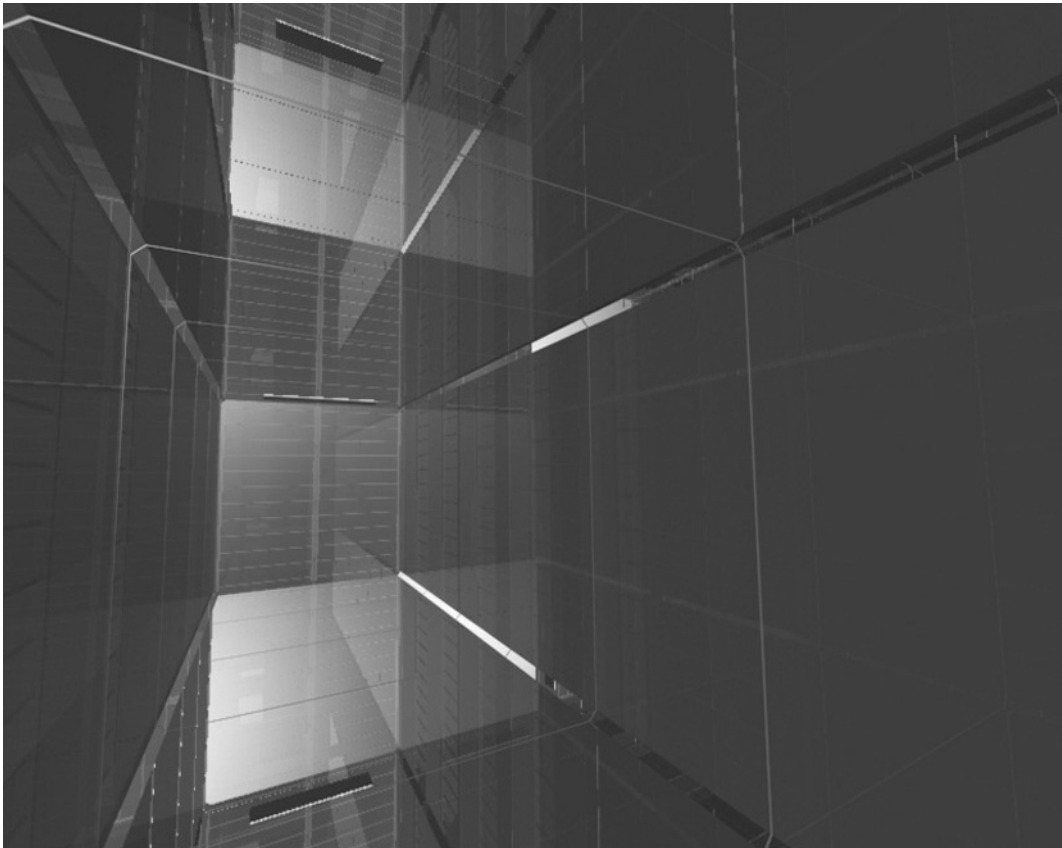

[Img. 20]

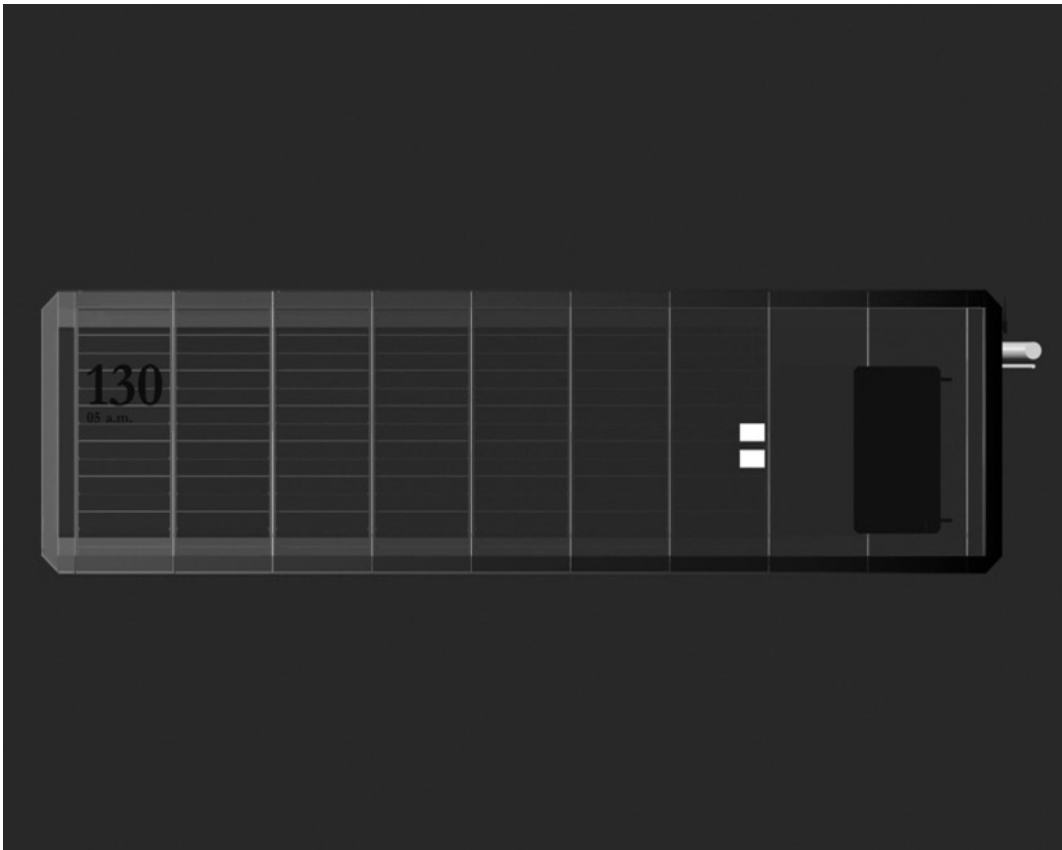

[Img. 21]

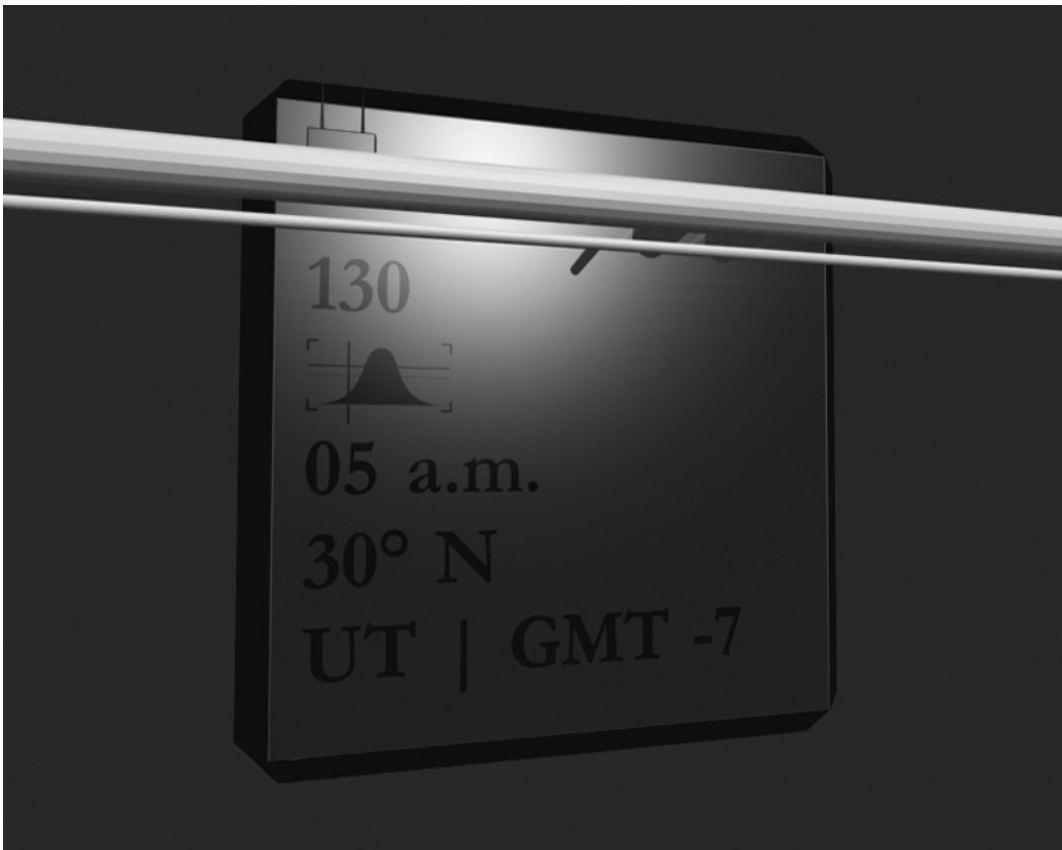

[Img. 22]



[Img. 23]

## **Nestlé World Headquarters, 2005**

**Insertion of RealRoom(s)**

[Img. 24]

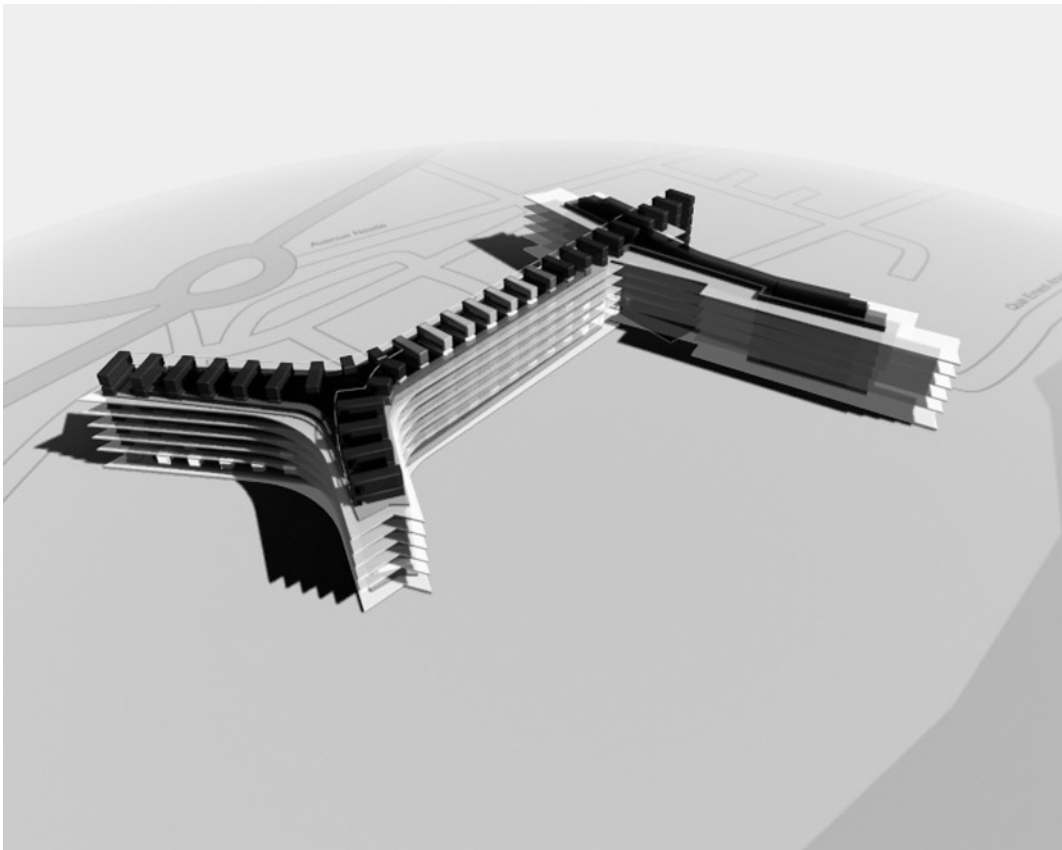

[Img. 25]

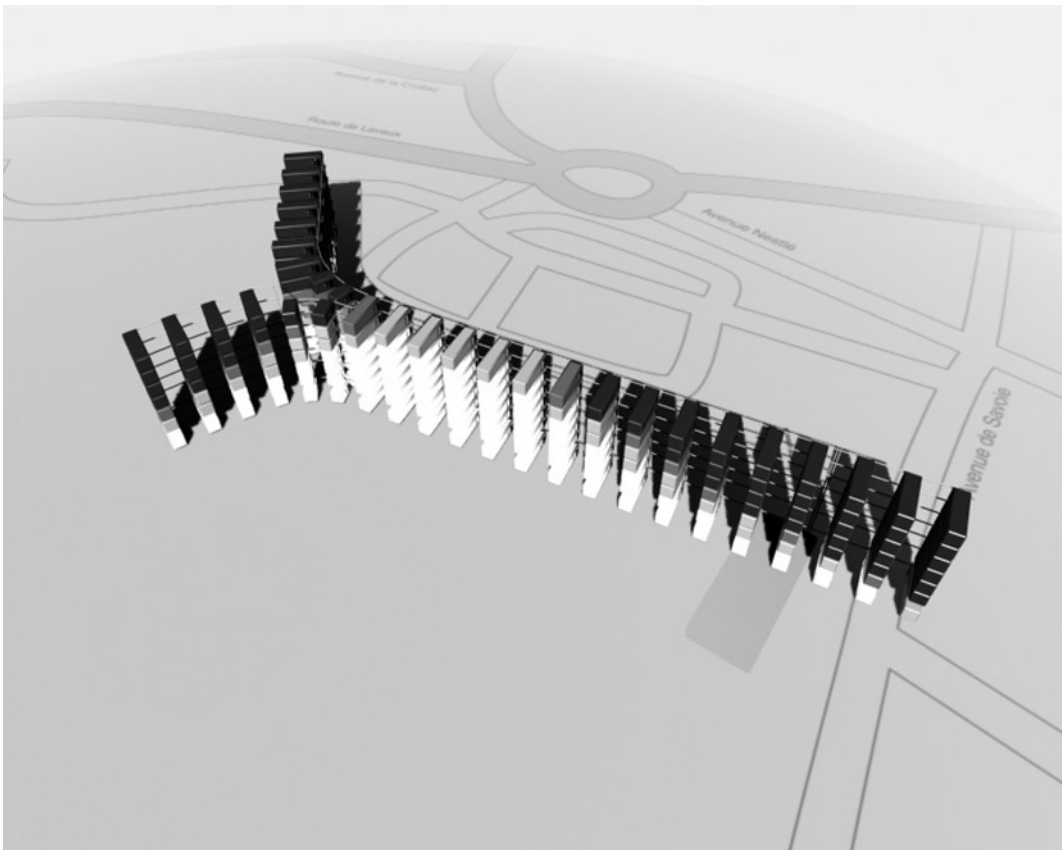

[Img. 26]

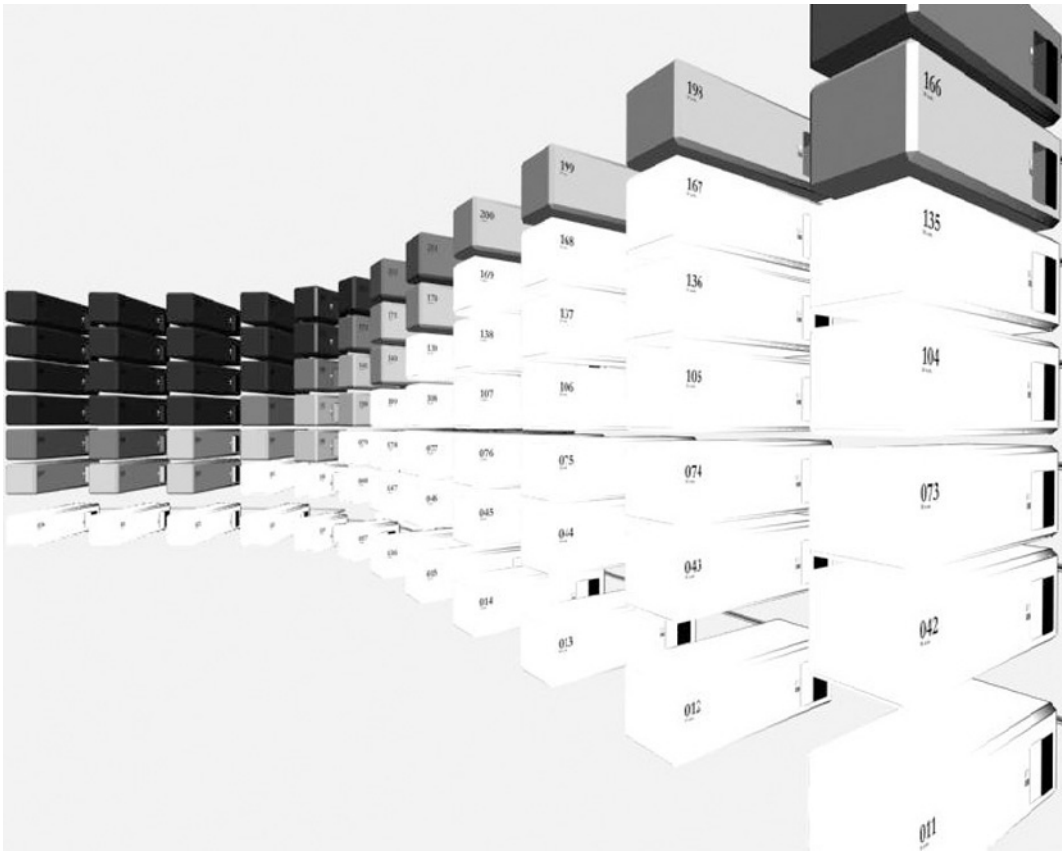

[Img. 27]



[Img. 28]

Terrestrial specialities

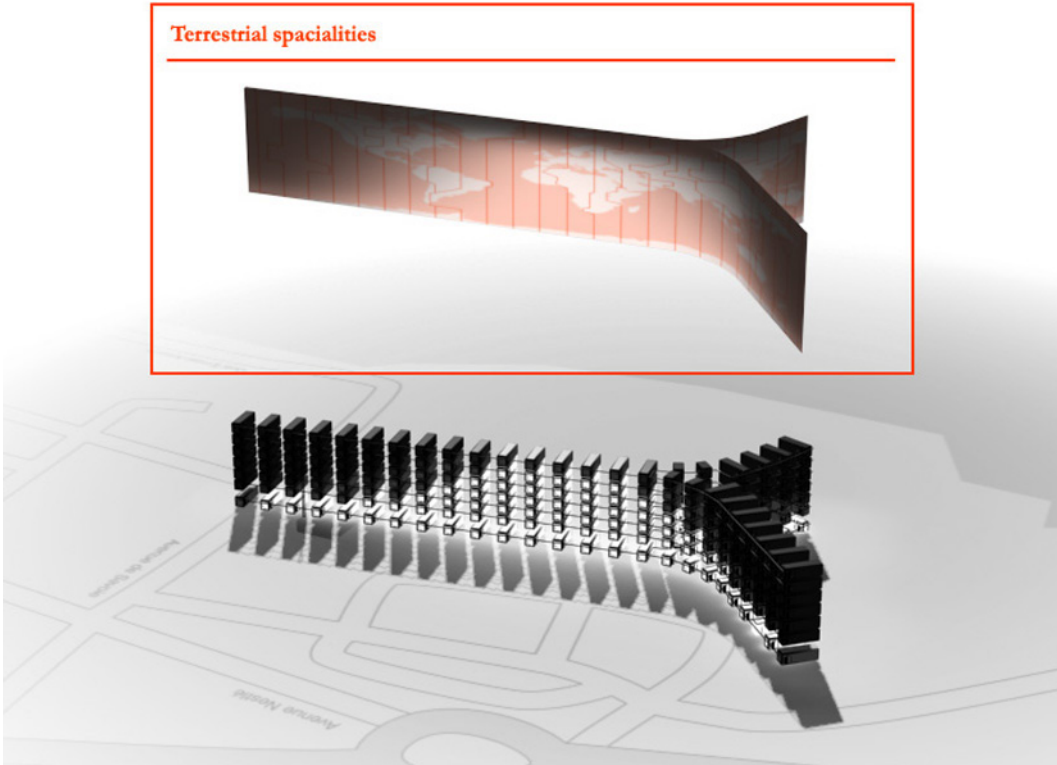

[Img. 29]

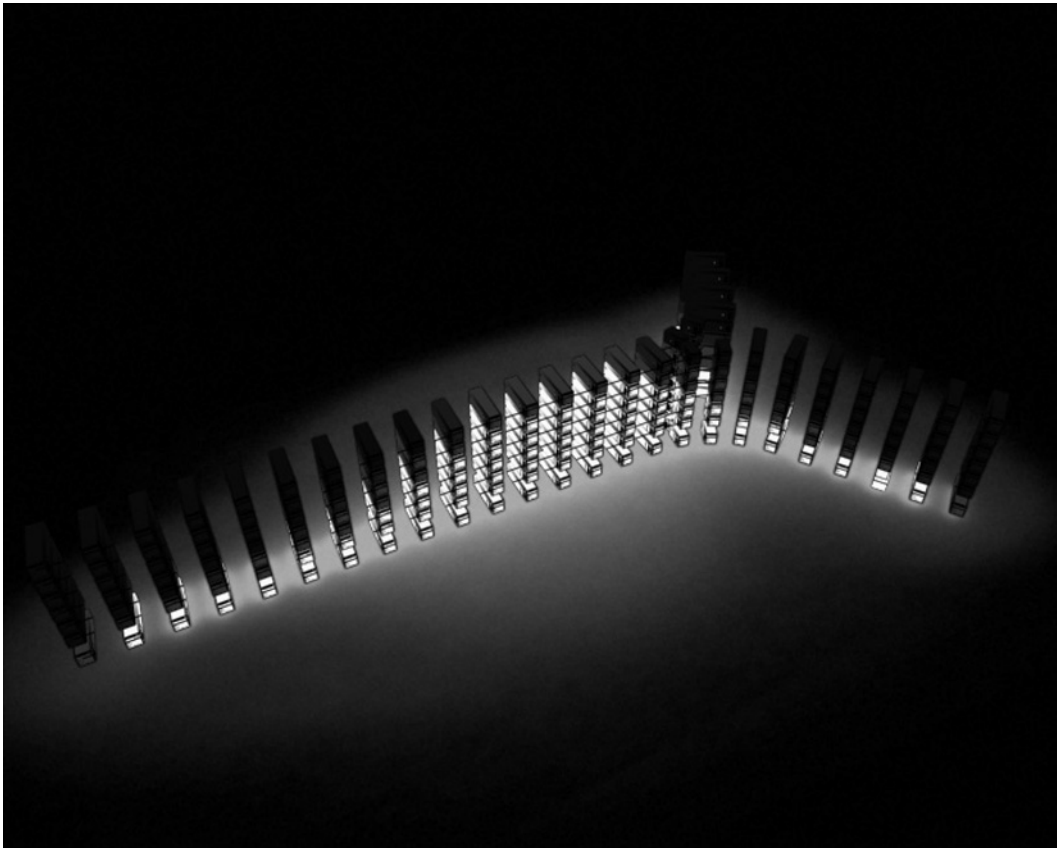

[Img. 30]

Image captions:

- [Img. 1] Video, title of the sequence about RealRoom(s). The project was presented during the exhibition 'Architecture invisible' at the Centre Culturel Suisse, Paris. The curator was architect Philippe Rahm.
- [Img. 2] Video, part1: analysis of Nestlé as a global brand.
- [Img. 3] Video, part 1: analysis of Nestlé as global brand. Sales.
- [Img. 4] Video, part 1: analysis of the Nestlé world headquarters (building by Swiss architect Jean Tschumi).
- [Img. 5] Video, part 1: conditioned areas in the existing building. Light conditioning and air conditioning.
- [Img. 6] Video, part 1: existing building as part of a global network.
- [Img. 7] Video, part 1: Nestlé "lives" in this network, on all continents & time zones simultaneously, contraction of time and space.
- [Img. 8] Video, part 2: focus on RealRoom(s) Nr 103 to 133.
- [Img. 9] Video, part 2: RealRoom(s) 130 (5:00 am), 131 (6:00 am), 132 (7:00 am), 133 (8:00 am). Front side view.
- [Img. 10] Video, part 2: RealRoom(s) 130 (5:00 am), 131 (6:00 am), 132 (7:00 am), 133 (8:00 am). Back side view.
- [Img. 11] Video, part 2: RealRoom(s) 132 (7:00 am space sample), side view.
- [Img. 12] Video, part 2: RealRoom(s) is a 100% conditioned space. It has a permanent connection with atomic clocks and weather stations. Time, temperature, humidity, and pressure conditions are captured from a specific source (a weather station) and reproduced in a RealRoom(s). It is a networked reality, an abstract, ubiquitous space.
- [Img. 13] Video, part 2: Same RealRoom(s), distant capture of luminosity.
- [Img. 14] Video, part 2: RealRoom(s) Nr 133 (8:00 am), 30° North. Unlike a real and located space, a global, abstract, and conditioned space can be highly variable. In this case, time is blocked forever: it is always 8:00 am in this specific RealRoom(s), but the illumination and air conditioning information are captured and streamed from time zone after time zone, moving to the "previous" time zone hour after hour, to stay always at 8:00 in the morning.
- [Img. 15] Video, part 2: RealRoom(s) 133, entering the space sample.
- [Img. 16] Video, part 2: RealRoom(s) 133, door from inside.
- [Img. 17] Video, part 2: RealRoom(s) 133, in the main space. What would be the function of a space in which it is always 8 o'clock in the morning? Sides of the main space are made of slightly dulled glass (equipped with polarizing LCD filters) and strong neon lights, floor and ceiling are made out of mirrors.
- [Img. 18] Video, part 2: RealRoom(s) 133, within the main space. Entrance view.
- [Img. 19] Video, part 2: RealRoom(s) 131, detail.
- [Img. 20] Video, part 2: RealRoom(s) 131, inside view.
- [Img. 21] Video, part 2: RealRoom(s) 130, 5:00 am, side elevation.
- [Img. 22] Video, part 2: RealRoom(s) 130, 5:00 am, 30° North.

- [Img. 23] Video, part 2: RealRoom(s) 130, inside view.
- [Img. 24] Video, part 3: insertion of RealRoom(s) in Nestlé's world headquarters.
- [Img. 25] Video, part 3: 217 RealRoom(s) are inserted into the building. Seven levels for seven latitudes (-90°, -60°, -30°, 0°, 30°, 60°, 90°), 24 + 1 RealRoom(s) by level for a full revolution of 24 hours (from 12 am to 12 pm). The insertion happens in the already artificially controlled zones of the building.
- [Img. 26] Video, part 3: the 217 RealRoom(s). Current & conditioned reality of the global earth updated every second. Night & day are present, as are cold & warm climates, deserts & poles, and so on.
- [Img. 27] Video, part 3: another view of some of the 217 RealRoom(s).
- [Img. 28] Video, part 3: a few RealRoom(s) from the other side with their number, time and latitude information.
- [Img. 29] Video, part 3: 217 RealRoom(s) are equivalent to a live, displaced & paradoxical terrestrial space.
- [Img. 30] Video, part 3: 217 RealRoom(s) at night.

---

# Txt

---

## RealRoom(s)

### RealRoom(s), Peripheral Architecture for the Nestlé World Headquarters

RealRoom(s) is an architectural project for the Nestlé World Headquarters in Vevey (Switzerland). This project proposes to insert a series of spatial entities into the air-conditioned intermediary areas at the very heart of the building. The RealRoom(s), informed by atomic clocks and luminosity, heat, pressure, and humidity sensors, are distributed in a regular framework across a space representing the entire globe (one RealRoom per time zone, on 0°, +/-30°, +/-60° and +/-90° latitude). These RealRoom(s), connected permanently, recreate directly in an artificial, but perceptible way, a global "terrestrial spatiality" fitting the scale of Nestlé in 2005.

With RealRoom(s), fabric | ch's intention is to propose new modes of architectural "presence" in a contemporary space which is not uniquely material and localized, but whose spatial spectrum covers a much wider field: from material to non-material, from visible to invisible, from habitable to uninhabitable, from located to distributed, from unique to ubiquitous.

From within several different time zones, day, and night, from North to South, at various latitudes, in cold and hot weather, each Nestlé office can exchange data, take part in the migration of information flow and work in a simultaneous manner: in a word, each office can exist today in a worldwide, variable and potentially multiple space. It is in this space, global in the true sense of the word, that the Nestlé World Headquarters are located, in a recently renovated building conceived in the early Sixties by Swiss architect Jean Tschumi.

Like many other contemporary administrative buildings in Tokyo, Paris, Rio de Janeiro and Berlin, the interior space of the Vevey building is artificially conditioned (electric lighting, air-conditioning systems, modern classic furniture and so forth). There is a kind of "global" consensus about what constitutes a "comfortable" space in which to work and live. There is a shift towards "100% artificial" spaces maintaining the same climatic, visual "comfort." RealRoom(s) does not propose to eliminate artificial spaces but, instead, to provide new ways to "inform" them, using a globally networked environment of data to create architectural "fictions." Indeed, the RealRoom(s) remain artificial. But first and foremost, these spatial entities become dynamic. Their architectural parameters vary in real time according to climatic, luminous, sound, and visual data, connected to various sources of information all over the globe.

RealRoom(s) invites us to consider this artificiality in its "worldwide-ness" or to consider the "100% artificial" space as a fundamentally global and abstract space, distinct from local and factual reality. Thus, RealRoom(s) is a way to conceive these "100% artificial" places in a global spatial spectrum, which considers the new parameters set by our transformed contemporary environment. Architectural concerns about the functionalism of spatial comfort are thus suspended.

RealRoom(s) is also a thinly veiled reference to a software which transformed the use of the Internet and diffused its content on the Web a few years ago: RealPlayer. Suddenly it was possible

to see videos ("RealVideo") or to listen to music ("RealAudio") in a continuous "stream" of data. It was also possible to receive images from distant cameras (webcams), filming continuously the same bit of planet, the same urban crossroads, or the same unknown place. Unlike RealPlayer, but by using the same process of continuously streaming information, the RealRoom(s) project proposes to "stream" reality (time zones, light, climate, and so on). It is now possible to encode all this data, transmit it through digital information networks and then to duplicate, multiply, and diffuse it as a potential information object and architectural component.

A RealRoom(s) prototype can thus be considered as a computer peripheral. However, instead of displaying images or printing documents on paper, this device is a spatial, architectural peripheral which can diffuse temporalities and places and interface light, sound, heat, humidity or information. This architectural data-processing peripheral can be connected to distant sources of information and can duplicate or multiply an existing situation. Above all, this peripheral spatiality can also create new architectural fictions, permitting one to block time, to hybridize climates, to live at a satellite rhythm or to connect luminous and climatic flows to oil or stock exchange prices, rather than merely duplicating the same "comfortable" controlled environments all over the globe. RealRoom(s) uses various elements of our physical space to suggest new situations - sometimes comfortable, but also uncomfortable, strange, playful, cognitive, or oblique.

In the context of this project for the Nestlé World Headquarters, each RealRoom(s) is blocked on a fixed hour, on a fixed latitude. To preserve this fixed situation, the information source of each RealRoom(s) changes hour by hour. In the space of 24 hours, a RealRoom(s) carries out a fictitious climatic and luminous round-the-world trip. It is always the same time and the same latitude in one of the RealRoom(s). Only the longitude of the source changes, hour by hour, permanently involving a slight modification of light and a more marked modification of humidity, heat, and sound. Thus, it produces a new spatiality, at the same time present and distant, built up by information collected from the physical, or "Real", world.

The "minor" circulation area of the Nestlé World Headquarters is devoid of any natural referent. Ideally, it is re-occupied here by a series of RealRoom(s) informed by real, "streamed" situations:

- Seven levels for seven latitudes (-90°, -60°, -30°, 0°, 30°, 60°, 90°)
- 24 + 1 RealRoom(s) by level for a full revolution of 24 hours (from 12 am to 12 pm).

Based on the morphology of the building, six time zones are duplicated to occupy the duplicated space on the second branch of the Y. Thus, there are 217 RealRoom(s), in total, invested in this intermediary space.

-

Rather like 217 slow satellites rotating every 24 hours around the Earth at ground level, collecting and transmitting information, RealRoom(s) reproduces a "terrestrial spatiality" with its extremes, its deserts, its seas, its poles, its cities, its days and its nights, its passing time. It is this vibrant, perceptible, "terrestrial spatiality," which is created in 217 samples of variable architecture in the artificial spaces of the Nestlé World Headquarters.

---

# Contact

---

fabric | ch (97-26)

**Architecture/Art direction:**

Patrick Keller

Christophe Guignard

-

**Technical/Technological direction:**

Christian Babski

Stéphane Carion

-

**Collaborators:**

Marc Escher

Franz Hoffman

**Contact:**

fabric | ch

6, rue de Langallerie

1003 Lausanne

Switzerland

-

[www.fabric.ch](http://www.fabric.ch)

-

t. +41(0)21-3511021 // f. +41(0)21-3511022 // m. info@fabric.ch